



# Design and Development of Wearable Posture Notifier (WeaPoN) and Human Body Motion Analyzer

Oliver J. Sepnio<sup>1</sup> and Alexander Co Abad<sup>1</sup>

<sup>1</sup> Department of Electronics and Computer Engineering, GCOE, De La Salle University – Manila, Philippines

\*Corresponding Author: [alexander.abad@dlsu.edu.ph](mailto:alexander.abad@dlsu.edu.ph)

**Abstract:** This study discusses the design and development of a Wearable Posture Notifier (WeaPoN) and human body motion analyzer with configurable thresholds. The prototype comprises a transmitter module and a receiver module that communicate with each other via ESP-NOW wireless communication. The transmitter module has a 6-axis accelerometer and gyroscope to measure body movements and acceleration in XYZ directions. Moreover, the receiver module has OLED screen to see the data coming from the transmitter and control knob to navigate and interact with the receiver module especially in changing the different thresholds and modes of operation (posture detection, idle detection or position timer, motion detection, and fall detection). The receiver module also has an aural or sound notification. The whole system can be used to detect body movements in terms of angles or inclinations, motions such as forward, backward, leftward, rightward, rotate left or right, or any movement combinations, and set limits or thresholds that will activate a notification for the user. It could also detect idleness or lack of movement by the user. Furthermore, the system could detect a sudden change in motion that might signify a fall or accident.

**Key Words:** wearable, embedded system, posture analyzer

## 1. INTRODUCTION

Body movement sensing and analysis are important in posture correction, pose or gesture recognition, and fall detection (Abad, et al., 2018). The ability to recognize and classify human posture is essential in many areas, including ergonomics, sports analysis, healthcare, human-computer interaction, and performing arts (Shen, et al., 2024). Body movement sensing could be grouped into two categories: 1) sensor-based embedded systems, and 2) optical-based systems or camera-based systems. Whatever sensing technology is used, body movements can be deduced from changes in the 3D space (pitch, roll, yaw) or XYZ planes of the coordinate system based on a reference plane and how fast these changes occur in a given period of time.

Camera-based systems for human pose estimation often encounter lighting, occlusion, and image processing challenges. Thus, sensor-based systems using pressure sensors, flex sensors, gyroscopes, accelerometers, or inertial measurement units (IMU) are often used, especially for outdoor and clinical monitoring (Kianifar, et al., 2019). Due to its small size, wearability, long-term data recording capabilities, affordability, and low power consumption, IMUs are ideal for motion measurement in clinical settings (Fong, et al., 2010).

Posture corrector braces help a person to maintain a proper posture, but sometimes they are cumbersome and uncomfortable to use, and the most effective posture correctors do not force your body into an abnormal stance. Instead, they serve as reminders to stand or sit properly (Chokrane, 2025). In line with

this concept, we developed a system that senses and measures body movements within a specified threshold and gives notifications or reminders for the user to adjust if the current posture is out of bounds.

In this work, a unified embedded system for Wearable Posture Notifier (WeaPoN) and a human body motion analyzer with adjustable thresholds is designed and developed. The system prototype consists of a transmitter module with an inertial measurement unit (IMU) and a receiver module that uses ESP-NOW wireless communication to exchange information. The transmitter module's 6-axis accelerometer and gyroscope can measure body movements and acceleration in XYZ directions. Additionally, the receiver module features an OLED screen to view the data from the transmitter and a control knob for navigating and interacting with the receiver module, particularly when adjusting the various thresholds and modes of operation (motion detection, fall detection, position timer, idle detection, and posture detection). This paper is divided as follows: Section 2 covers the construction of the prototype, followed by results and discussion in Section 3, and conclusion and recommendation in Section 4.

## 2. DESIGN AND CONSTRUCTION OF THE PROTOTYPE

### 2.1 System Overview

The block diagram of the whole system, as shown in Fig. 1, comprises a wireless transmitter module that sends gyroscope and acceleration data in the XYZ plane and a receiver module that processes the received data, displays it, and notifies the user if the motion thresholds have been reached. The 3D system structure and the actual pictures of the transmitter and receiver modules are shown in Fig. 2. The different modules will be discussed in the following sections.

### 2.2. Transmitter Module

This rechargeable module comprises a 6-axis accelerometer and gyro (MPU6050), an ESP32C3 dev board, and battery charger sub-modules. The module also consists of an ON/OFF push button power key, power and full charge LED indicators, and a USB Type-C port. The transmitter orientation (green LED at the bottom) and sub-modules are shown in Fig. 3.

The 6-axis accelerometer and gyro sub-module is responsible for continuous calculation of the XYZ orientation angles of the module, data filtering, processing, and sending data to the ESP32C3 microcontroller for transmitting the data wirelessly.

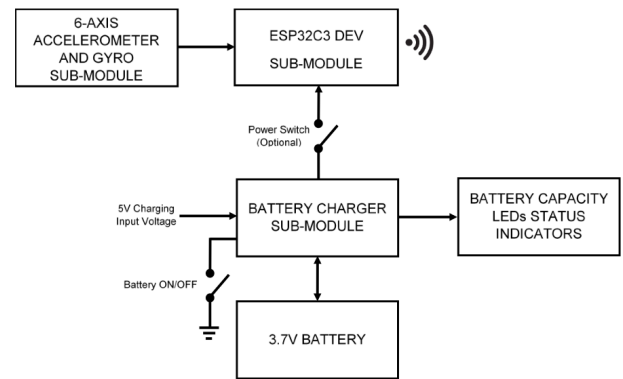

a) Transmitter Module Block Diagram

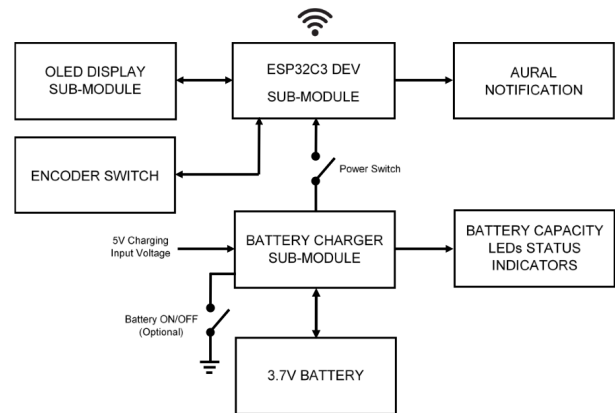

b) Receiver Module Block Diagram

Fig. 1. Block diagram of the whole system: a) transmitter and b) receiver

However, a 1-minute set-up time is needed for the gyro and accelerometer sensor to stabilize. The ESP32C3 sub-module is responsible for receiving processed data from the accelerometer and gyro, stability timer, conditioning, and formatting the data before transmission using the ESPNOW protocol, acting as the MASTER. The sub-module also provides the supply voltage needed by the accelerometer and gyro sub-module through its internal regulator circuit.

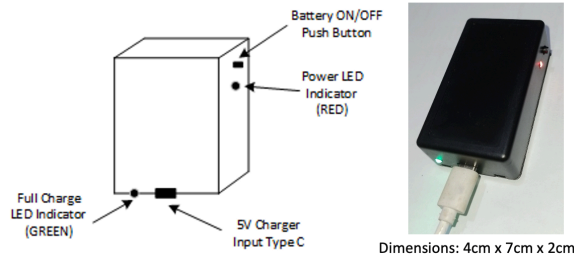

**Transmitter Module**

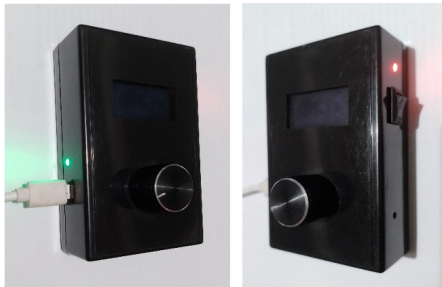
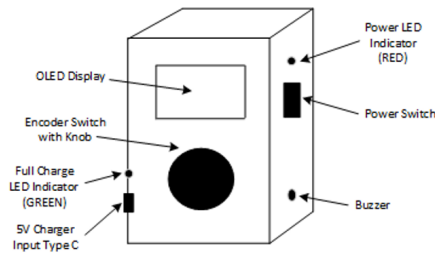

Dimensions: 10cm x 6cm x 3cm

**Receiver Module**

Fig. 2. The 3D system structure and actual pictures of the transmitter and receiver modules.

The IMU angles are sampled at 10 Hz, and the transmitter sends the average measured angles every second.

In addition, the module also consists of a battery charger sub-module that manages the battery charging and provides battery capacity LED indicators (i.e. power and full charge LEDs). It can supply voltage to the ESP32C3 microcontroller and charge the battery simultaneously with a charging voltage on the module. Power and full-charge LED indicators signify the battery charge level. Blinking power LED signifies less than 25% battery level, while

a steady full charge LED indicator signifies 100% battery level.

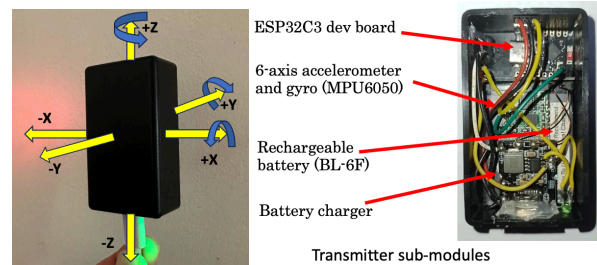

Fig. 3. The transmitter orientation and sub-modules.

Moreover, a power key tact switch is also provided on the module for powering ON or OFF of the module, and a USB Type-C port is available for charging the battery of the module either using the mobile phone USB-C charger adapter or power banks.

Finally, the location of the module can be either in front or at the back of the user's body, depending on the preference, purpose of detection, and/or comfort of the user.

### 3.3 Receiver Module

As shown in Fig. 4, this rechargeable module comprises an OLED display sub-module, an ESP32C3 dev board, and a battery charger sub-module. The module also consists of a multi-function encoder switch, aural notification, an ON/OFF power rocker switch, power and full charge LED indicators, and a USB Type-C port.

The OLED sub-module display is used for the visual presentation of the data to the user. The data provided by the module is presented as Main and Configuration Displays.

Main Display data are presented on a sequential page format, ANGLES (XYZ angles of the Transmitter Module), DELTAs (dX, dY and dZ rate of change of angles), MOVEMENT (Movement detection such as forward, backward, leftward, rightward, twisted left, twisted right, combination of mentioned movements and idle position detection), FALL, MOTION, and POSTURE (user's posture position detection and notification).

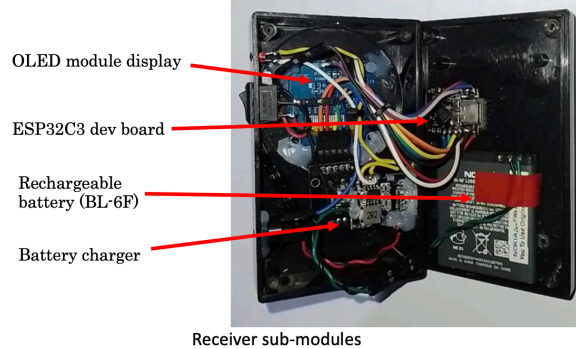

Fig. 4. The receiver sub-modules.

The ESP32C3 sub-module is responsible for receiving processed data from the accelerometer and gyro, stability timer, conditioning, and formatting the data prior to transmission using the ESPNOW protocol, acting as the SLAVE. The sub-module also provides the supply voltage needed by the accelerometer and gyro sub-module through its internal regulator circuit.

The module also provides a multi-function encoder switch for accessing different displays and pages by long pressing the encoder knob (i.e. changing Main to Configuration Display or vice versa). In addition, changing carousel pages either on Main or Configuration display can be done by rotating the encoder knob on clockwise or counter clockwise direction and same concept is used when modifying or changing the values of the selected parameter on Configuration display. However, selecting a parameter to edit the value on Configuration display is done by short pressing the encoder knob. All the modified settings on the Configuration display are temporary until the module is returned to the Main display. Upon exiting the Configuration display, all the settings are saved in the microcontroller memory and loaded upon start or boot-up of the module.

Moreover, the module provides an active buzzer as an aural encoder switch rotation and select switch sound notifications that can be enabled or disabled on the Configuration display depending on the user's preference.

Similar to the Transmitter module described in the previous section, this module has similar features as far as the battery charger sub-module is concerned. The battery charger sub-module manages

the battery charging and provides battery capacity LED indicators (i.e., power and full charge LEDs), whereas the power and full charge LED indicators signify the battery charge level. Such as a blinking power LED signifies less than 25% battery level, while a steady full charge LED indicator signifies 100% battery level, respectively. The battery charger sub-module can supply voltage to the ESP32C3 microcontroller, OLED display, and charge the battery simultaneously with a charging voltage on the module. In addition, a power key rocker switch is also available on the module for powering ON or OFF the module, and a USB Type-C port is provided for charging the module's battery either using a mobile phone USB-C charger adapter or power banks.

### 3. RESULTS AND DISCUSSION

The Transmitter module can be attached to the back, as shown in Fig. 5, or the chest of the user's body using medical double-sided tape or a rubber strap to hold the module in place. The module can be placed in any location since it is wirelessly operated. However, the ideal module location should be placed where the user can read the OLED screen data and/or hear the aural notification within the wireless communication range.



Fig. 5. Transmitter module at the back of the user.



Fig. 6. Boot-up Displays

Upon booting up or powering ON the Receiver module, the device will display the welcome screen, as shown in Fig. 6, in sequence while loading the saved settings from the memory of the microcontroller.

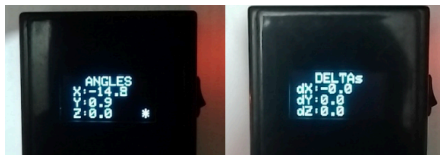

Fig. 7. Main Displays (ANGLES and DELTAs)

The ANGLES screen page, as shown in Fig. 7, displays the XYZ angle orientation, in degrees, of the sensor of the Transmitter module, while the DELTAs screen displays the rate of change of angles per 500ms as the Transmitter module senses motion or movement of the body of the user.

The MOVEMENT screen page, as shown in Fig. 8, displays the motion sensed by the sensor based on the rate of change of angles per 500ms (i.e., moving Forward, Backward, Leftward, Rightward, Left twist, Right twist, and combination of movements). In the case of IDLE DET (idleness or no movement detection) on the Configuration page is enabled, a notification screen is displayed when the idle counter is equal to the set idle duration. An aural notification will activate if the notification is enabled on the Configuration display NOTIF (notification) page.



Fig. 8. Main Displays (MOVEMENT)



Fig. 9. Fall detection

Fall detection can be enabled, as shown in Fig. 9, and can be deduced from the sudden or abrupt change of values of at least one of the enabled DELTAs

(XYZ parameters per 500ms). When the fall detection threshold is reached, the aural notification at the receiver module is activated.



Fig. 10. Motion detection

Moreover, the system prototype could be used as a motion detection device, as shown in Fig. 10. The transmitter module can be placed on an object where motion needs to be sensed, such as a baby crib. In contrast with movement detection, which can differentiate between different movements, the motion detection mode can only be either motion detected or not, depending on the set thresholds.



Fig. 11. Main Displays (POSTURE)

The POSTURE screen page, as shown in Fig. 11, displays the user's position in reference to the set XYZ angle limits. If the user position is within the limits, a GOOD POSITION will be shown. Otherwise, the display will be the positions outside the set limits. On the other hand, no posture detection will be performed if the POST DET on the Configuration page is disabled. Similar to the MOVEMENT screen displays, an aural notification will activate if the notification is enabled.

As shown in Fig. 12, the Configuration limits screen pages are used to set thresholds or limits on the user's 3-axis movement. Limits can be set all or individually, depending on the user's needs or requirements. Six (6) movement limits on sequential screen pages can be set on the Configuration display (such as 1) FWD LIMIT (for forward movement limit), 2) BCK LIMIT (for backward movement limit), 3) LWRD LIMIT (for leftward movement limit), 4) RWRD LIMIT (for rightward movement limit), 5) TW-



L LIMIT (for Left twist movement limit), and 6) TW-R LIMIT (for Right twist movement limit)).



Fig. 12. Configuration Limits Display for the user's 3-axis movement.

Each configuration limit screen consists of two (2) or three (3) rows of text. The first row of text states the movement limit to set, and the second row of text is the measured angle data of the specific axis involved in the movement. However, the third line of text represents the angle limit saved in the memory of the microcontroller. Absence of the third line of text signifies that there is no saved angle limit on the selected parameter and will be excluded from the posture detection. Saved angle data can be removed or modified by short pressing the encoder knob. These movement limits are the basis of the calculation for the posture detection. Setting all the movement limits on a good posture threshold position will restrict the user's movement on a confined XYZ motion space, thus the user can avoid unnoticed bad posture situations.

The Thresholds and Miscellaneous settings screen is also provided by the device to optimize the performance of the system according to the user's preferences.

Thresholds and sensitivity are available in the device settings to filter unwanted variations in the data or high sensitivity on the user's movement. MOVE THRES and MOVE SENS pages, as shown in

Fig. 13, are used to increase or decrease the motion rate of change and motion occurrence count, respectively, for movement calculation and recognition.

However, IDLE DET and IDLE DUR pages are intended to detect idle time in one position of the user (i.e., sitting or standing in one position for a very long duration). On the other hand, the LIMIT SENS page is used to increase or decrease the occurrence count over or under the set limits for posture calculation and detection. In addition, the POST DET page is used to enable or disable the posture detection of the user's body



Fig. 13. Configuration Limits Display for movement detection, idle detection, and posture detection.



Fig. 14. Configuration Thresholds and Miscellaneous Settings

Moreover, the Transmitter module location, either FRONT or BACK, should be set on the

SENSOR LOC page, as shown in Fig. 14, for correct data calculation and position detection of the device.

Furthermore, the timeout duration for the event of absence of received valid data before displaying the notification screen can be set on the RX TIMEOUT page. Adjusting the screen contrast for clarity of displayed text by setting it to LOW, MEDIUM, or HIGH can be done on the CONTRAST page, and the NOTIF page can be used to enable or disable aural notification.

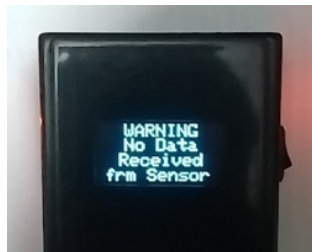

Fig. 15. Receiver Timeout Display

On an event that the Transmitter module stop sending data, powered OFF or sending garbage data due to LOW power condition, congested Wi-Fi signals on the area or out of range location, the Main display of the receiver will be overwritten with the notification or warning on the screen, as shown on Fig. 15. Aural alarm activation will depend on the setting on Configuration display NOTIF page.



Fig. 16. Configuration Hash “#” Sign Display (Receive Timeout Condition)

In the absence of valid received data as mentioned in the previous section, the notification screen is displayed on the Main display while the hash

sign “#” is displayed on the Configuration display, as shown in Fig. 16, and its corresponding setting screen pages. In addition, all angle data are set to 0.0 values.



Fig. 17. Configuration Asterisk “\*” Sign Display (Unstable Sensor Data Condition)

In the event of unstable Transmitter module sensor data, an asterisk “\*” sign will be displayed on all screens and pages of the device, as shown in Fig. 17.

Table 1 shows a summary of the different modes and configurations of the system prototype. There are the MAIN display page with different screen pages, the CONFIG or configuration display, and the MISC or miscellaneous display page. All of these screen pages can be explored using the carousel knob that can rotate clockwise and counterclockwise with a built-in push button switch.

Table 1. Summary of the different modes and configurations.

Display	Page	Screen Name	Parameters	Aural Notif	Configuration Controlling Parameters
MAIN	1	ANGLES	X, Y and Z angles	N/A	N/A
	2	DELTA	dx, dy and dz	N/A	N/A
	3	MOVEMENT	None, Forward, Backward, Leftward, Rightward, Twisted-L, Twisted-R or combinations	N/A	MOVE THRES and MOVE SENSE
			Idle Time Duration Reached	YES	IDLE DET and IDLE DUR
	4	FALL	Detection Enabled, Detection Disabled, Detected	YES	DX THRES, DY THRES, DZ THRES and FALL DET
	5	MOTION	Detection Enabled, Detection Disabled, Detected	YES	MOVE THRES, MOVE SENSE and MOTION DET
6	POSTURE	Detection Disabled, Good Position, Forward, Backward, Leftward, Rightward, Twisted-L, Twisted-R or combinations	YES	LIMIT SENSE and POST DET	



Display	Page	Screen Name	Values	Knob Sound If NOTIF is Enabled	Controlled Main Display
CONFIG	1	FWD LIMIT	-90 to 90 deg	YES	POSTURE
	2	BCK LIMIT	-90 to 90 deg		
	3	LWRD LIMIT	-80 to 80 deg		
	4	RWRD LIMIT	-80 to 80 deg		
	5	TW-L LIMIT	0 to 360 deg		
	6	TW-R LIMIT	0 to 360 deg		
	7	DX THRES	0 to 180 deg/Disable	YES	FALL
	8	DY THRES	0 to 180 deg/Disable		
	9	DZ THRES	0 to 180 deg/Disable		
	10	FALL DET	Enabled and Disabled	YES	FALL
	11	M OVE THRES	0 to 99.9 deg	YES	MOVEMENT and MOTION
	12	M OVE SENSE	1 to 10 counts	YES	MOVEMENT and MOTION
	13	MOTION DET	Enabled and Disabled	YES	MOTION
	14	IDLE DUR	1 to 999 mins	YES	MOVEMENT
	15	IDLE DET	Enabled and Disabled	YES	MOVEMENT
	16	LIMIT SENS	1 to 10 counts	YES	POSTURE
	17	POST DET	Enabled and Disabled	YES	POSTURE
	18	SENSOR LOC	Front and Back	Yes	MOVEMENT, FALL, MOTION and POSTURE
	19	RX TIMEOUT	1 to 10 secs	YES	N/A
	20	CONTRAST	Low, Medium and High	YES	N/A
	21	NOTIF	Enabled and Disabled	YES	All Display Screens

Display	Screen Name	Occurrence	Duration	Controlling Configuration Parameter
MISC	Wearable Posture Notifier	1st Boot up Sequence	3 secs	Fixed
	Human Body Logo	2nd Boot up Sequence	3 secs	Fixed
	WARNING No Data Received frm Sensor	No valid data for the duration of timeout setting	1 to 10 secs	RX TIMEOUT
	Hash Symbol	No valid data for the duration of timeout setting	Displayed on all MAIN and CONFIG Screens all the time	RX TIMEOUT
	Asterisk Symbol	Unstable sensor data visual notification	Displayed on all MAIN and CONFIG Screens usually 1 minute duration	Depends on Acc and Gyro Sensor of Transmitter Module

## 4. CONCLUSION

This study discussed the design and development of a sensor-based Wearable Posture Notifier (WeaPoN) and human body motion analyzer with configurable thresholds. The prototype has a transmitter module that has MPU6050 inertial measurement unit that gathers motion and acceleration parameters and transmit them via ESP-NOW wireless communication to a receiver module that has OLED screen to see the data coming from the transmitter and control knob to navigate and interact with the receiver module especially in changing the different thresholds and modes of operation (posture detection, idle detection or position timer, motion and fall detection). The receiver module also has an aural or sound notification. The whole system can be used to detect body movements in terms of angles or inclinations, motions such as forward, backward,

leftward, rightward, rotate left or right or any movement combinations, and set limits or thresholds that will activate a notification for the user. It could also detect idleness or lack of movement by the user. Furthermore, the system could detect a sudden change in motion that might signify a fall or accident.

The system could also be a motion sensor for moving objects, such as a baby crib, and a motion capture device for entertainment arts. It could also be used as a digital inclinometer to measure tilt and slopes.

## 5. ACKNOWLEDGMENT

The authors would like to thank DOST-ERDT for supporting this study.

## 6. REFERENCES

- Abad, A. C., Cunanan, A. M. V. T., Ambion, P. M. M., Harris, E. . L. (July 2018), Design and Development of a Posture and Fall Analyzer, Conference: 33rd International Technical Conference on Circuits/Systems, Computers and Communications (ITC-CSCC) 2018, Bangkok, Thailand, July 4-7, 2018.
- Shen J., Chen L. Application of Human Posture Recognition and Classification in Performing Arts Education. IEEE Access. 2024; 12: 125906-125919. doi: 10.1109/access.2024.3451172
- Kianifar, R., Joukov, V., Lee,A, Raina,S, Kulić,D. Inertial measurement unit-based pos estimation: Analyzing and reducing sensitivity to sensor placement and body measures, Journal of Rehabilitation and Assistive Technologies Engineering. 2019; Vol. 6.
- Fong DT-P, Chan Y-Y. The Use of Wearable Inertial Motion Sensors in Human Lower Limb Biomechanics Studies: A Systematic Review. Sensors. 2010; 10(12):11556-11565. <https://doi.org/10.3390/s101211556>
- Chokrane, B. (2025). The Best Posture Correctors, GEAR. <https://www.wired.com/gallery/posture-correctors/>